

MV-CB013-A0UM/UC

1.3 MP 1/2" CMOS USB3.0 Board Level Camera



GEN*i*CAM

USBTM
VISION

Introduction

MV-CB013-A0UM/UC camera adopts CMOS sensor to provide high-quality images. It uses USB3.0 interface to transmit non-compressed images in real time, and its max. frame rate can reach 201 fps in full resolution. With single board design, it is small in size, which can meet different spatial requirements.

Key Feature

- Compact design for flexible installation.
- Supports auto or manual adjustment of gain, exposure time, white balance, Gamma correction, LUT, etc.
- Adopts image interpolation algorithm for color cameras to have better color correction.
- Adopts USB3.0 interface to provide power supply and transmit data.
- Compatible with USB3 Vision Protocol, GenICam standard, and third-party software based on these protocol and standard.

Available Model

- Single board mono camera: MV-CB013-A0UM-B
- C-mount mono camera: MV-CB013-A0UM-C
- C-mount color camera: MV-CB013-A0UC-C
- M12-mount mono camera: MV-CB013-A0UM-S
- M12-mount color camera: MV-CB013-A0UC-S

Applicable Industry

Electronic semiconductor, factory automation, logistics, bottle detection, medicine packing, etc.

Sensor Quantum Efficiency

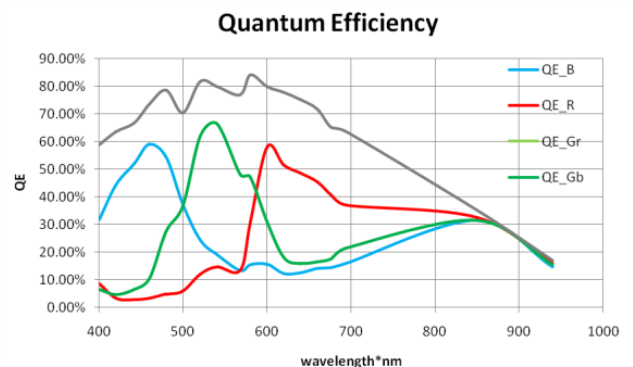

Specification

Model	MV-CB013-A0UM	MV-CB013-A0UC
Camera		
Sensor type	CMOS, global shutter	
Pixel size	4.8 μm × 4.8 μm	
Sensor size	1/2"	
Resolution	1280 × 1024	
Max. frame rate	201 fps @1280 × 1024	
Dynamic range	53 dB	
SNR	40 dB	
Gain	0 dB to 16 dB	
Exposure time	9 μs to 10 sec	
Exposure mode	Off/ Once/ Continuous exposure mode	
Mono/color	Mono	Color
Pixel format	Mono 8/10/10p/12/12p	Mono 8/10/12, Bayer GB 8/10/10p/12/12p YUV422Packed, YUV422_YUYV_Packed, RGB 8, BGR 8
Binning	Supports 1 × 1, 2 × 2, 4 × 4	
Decimation	Supports 1 × 1, 2 × 2, 4 × 4	
Reverse image	Supports horizontal and vertical reverse image output	
Electrical features		
Data interface	USB3.0	
Digital I/O	Bi-directional non-isolated I/O × 2 (Line 2, Line 5)	
Power supply	USB3.0 power supply	
Power consumption	Typ. 1.6 W@5 VDC (USB3.0 provides power supply)	Typ. 2.8 W@5 VDC (USB3.0 provides power supply)
Mechanical		
Lens mount	Single board camera: None C-mount camera: C-mount M12-mount camera: M12-mount	C-mount camera: C-mount M12-mount camera: M12-mount
Dimension	Single board camera: 32.5 mm × 32.5 mm × 1.6 mm (1.3" × 1.3" × 0.1") C-mount camera: 35 mm × 35 mm × 8.6 mm (1.4" × 1.4" × 0.3") M12-mount camera: 35 mm × 35 mm × 8.6 mm (1.4" × 1.4" × 0.3")	C-mount camera: 35 mm × 35 mm × 8.6 mm (1.4" × 1.4" × 0.3") M12-mount camera: 35 mm × 35 mm × 8.6 mm (1.4" × 1.4" × 0.3")
Weight	Single board camera: Approx. 10 g (0.02 lb.) C-mount camera: Approx. 30 g (0.07 lb.) M12-mount camera: Approx. 30 g (0.07 lb.)	C-mount camera: Approx. 30 g (0.07 lb.) M12-mount camera: Approx. 30 g (0.07 lb.)
Temperature	Working temperature: 0 °C to 50 °C (32 °F to 122 °F) Storage temperature: -30 °C to 70 °C (-22 °F to 158 °F)	
Humidity	20% to 80% RH, non-condensing	
General		
Client software	MVS or third-party software compatible with USB3 Vision Protocol	
Operating system	32/64-bit Windows XP/7/10, 32/64-bit Linux, and 64-bit MacOS	
Compatibility	USB3 Vision, GenICam	
Certification	CE, FCC, RoHS, KC	

Dimension

Single board camera:

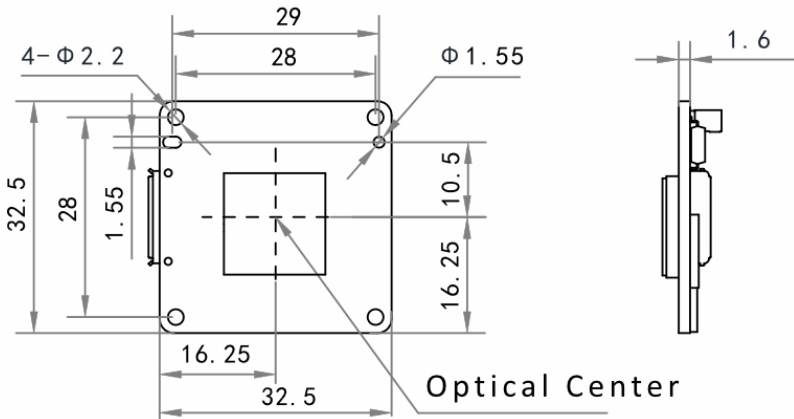

Unit: mm

C-mount camera:

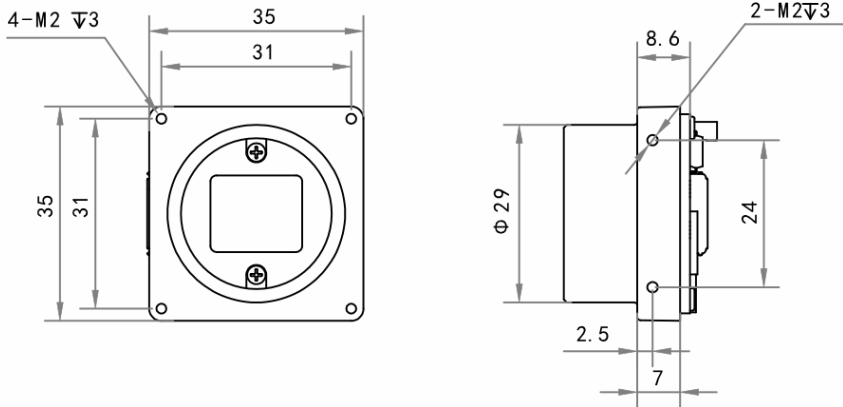

Unit: mm

M12-mount camera:

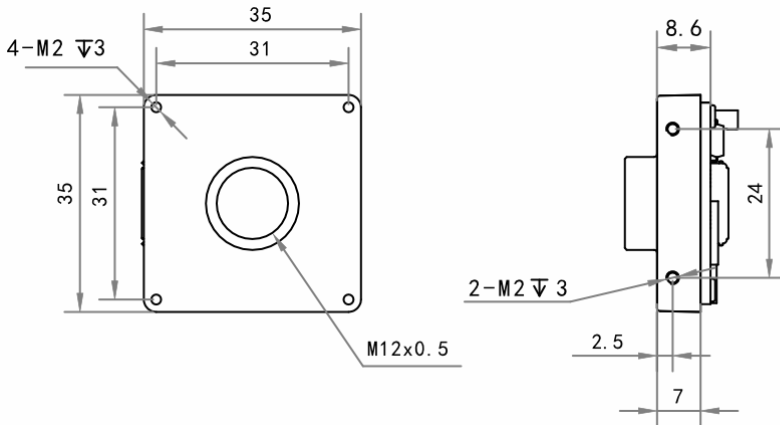

Unit: mm

HIKROBOT

Hangzhou Hikrobot Co., Ltd.
en.hikrobotics.com