

MV-ID5030M

3.1 MP Smart Code Reader



Introduction

MV-ID5030M smart code reader can read different types of codes with reading speed up to 90 codes/sec. It adopts Hikrobot's deep learning algorithm to process images with good robustness, and can recognize various complex codes.

Key Feature

- Adopts built-in deep learning algorithm to read codes with good robustness.
- Adopts CMOS global shutter sensor to provide high quality images.
- Adopts mechanical autofocus lens to achieve automatic focusing.
- Supports code score and quality evaluation for code printing quality.
- Adopts controllable light source design providing diversified light.
- Ingress protection rating 67.

Applicable Industry

Consumer electronics, food and beverage, pharmaceutical, semiconductor, automobile, new energy, etc.

Available Model

- 8 mm focal length: MV-ID5030M-08S-WBN
- 12 mm focal length: MV-ID5030M-12S-WBN
- 16 mm focal length: MV-ID5030M-16S-WBN
- 25 mm focal length: MV-ID5030M-25S-WBN

Dimension

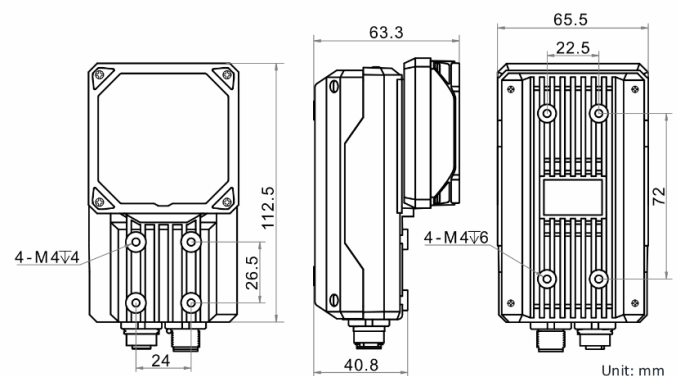

Specification

Model	MV-ID5030M-08S-WBN	MV-ID5030M-12S-WBN	MV-ID5030M-16S-WBN	MV-ID5030M-25S-WBN
Performance				
Symbologies	1-dimensional codes: Code 39, Code 93, Code 128, CodaBar, EAN 8, EAN 13, UPCA, UPCE, ITF 14, ITF 25, Matrix 25, MSI, China Post, Code 11, and Industrial 25			
	2-dimensional codes: QR Code, Data Matrix			
	Stack codes: PDF 417			
Max. frame rate	60 fps			
Max. reading speed	90 codes/sec			
Sensor type	CMOS, global shutter			
Pixel size	2.5 μm \times 2.5 μm			
Sensor size	1/2"			
Resolution	2048 \times 1536			
Exposure time	16 μs to 1 sec			
Gain	1 dB to 4 dB			
Mono/color	Mono			
Communication protocol	SmartSDK, TCP Client, TCP Server, Serial, FTP, Profinet, Ethernet/IP, MELSEC, ModBus, Fins, SLMP, UDP			
Electrical feature				
Data interface	Gigabit Ethernet			
Digital I/O	12-pin M12 connector provides power and I/O, including opto-isolated input (LineIn 0/1/2) \times 3, opto-isolated output (LineOut 3/4/5) \times 3, RS-232 input \times 1, and RS-232 output \times 1.			
Power supply	24 VDC			
Max. power consumption	60 W@24 VDC (light source enabled)			
Mechanical				
Focal length	8 mm (0.3")	12 mm (0.5")	16 mm (0.6")	25 mm (1.0")
Lens mount	M12-mount, mechanical autofocus supported.			
Lens cap	Half polarization lens cap by default. Transparent and full polarization lens cap are optional.			
Light source	White light by default. Red/blue/IR light is optional.			
Indicator	Power indicator (PWR), network indicator (LNK/ACT), and user-defined indicator (U1/U2).			
Dimension	112.5 mm \times 65.5 mm \times 63.3 mm (4.4" \times 2.6" \times 2.5")			
Weight	Approx. 450 g (1.0 lb.)			
Ingress protection	IP67 (under proper installation of waterproof lens cap)			
Temperature	Working temperature: 0 $^{\circ}\text{C}$ to 50 $^{\circ}\text{C}$ (32 $^{\circ}\text{F}$ to 122 $^{\circ}\text{F}$) Storage temperature: -30 $^{\circ}\text{C}$ to 70 $^{\circ}\text{C}$ (-22 $^{\circ}\text{F}$ to 158 $^{\circ}\text{F}$)			
Humidity	20% to 95% RH, non-condensing			
General				
Client software	IDMVS			
Certification	CE, FCC, RoHS, KC			

HIKROBOT

Hangzhou Hikrobot Co., Ltd.
en.hikrobotics.com

© Hangzhou Hikrobot Co., Ltd. All Rights Reserved.

Hangzhou Hikrobot does not tolerate any infringement. Any organization or individual may not imitate or reproduce in whole or in part of the content. The data herein is based on Hikrobot's internal evaluation. Actual data may vary depending on specific configuration and operating condition. The information herein is subject to change without notice. All the content has been checked conscientiously. Nevertheless, Hikrobot shall not be liable to damages resulting from errors, inconsistencies or omissions.