

**MVL-HF1628-05S**  
**16mm F2.8 M12 Mount Lens**

M12 series lens is designed for machine vision applications with excellent imaging quality from near to infinity. It is suitable for board cameras with different resolutions. Adapt for measurement, positioning, defect detection, code scanning and other fields.



**Key Features**

- Optimization design for machine vision
- High resolution, High consistency of picture definition
- Low Distortion, High relative illumination
- S-Mount (M12 \* 0.5), Easy system integration

**Dimension**

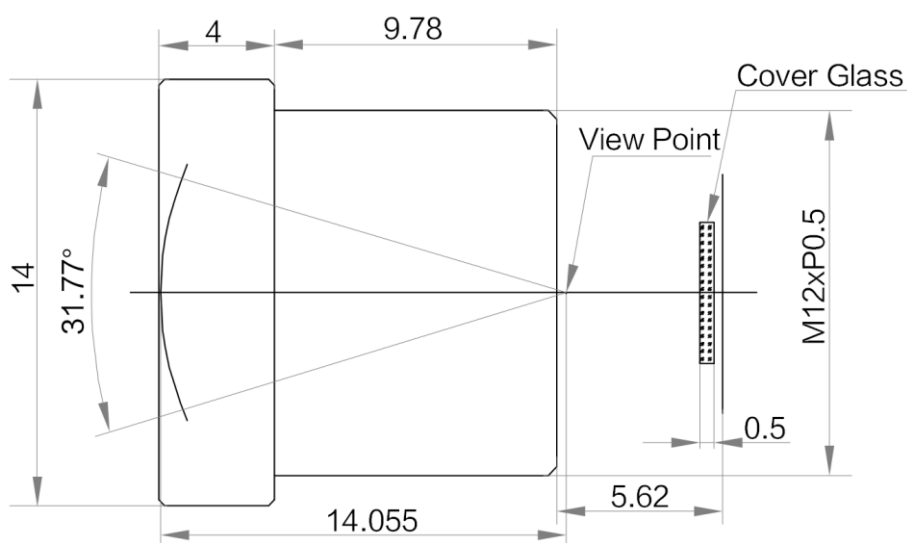

Unit: mm



## Specification

Parameter	Model	MVL-HF1628-05S
		16mm F2.8 M12 Mount Lens
<b>Performance</b>		
Focal Length		16 mm
F-Number		F2.8
Image Size		Φ9 mm(1/1.8")
TV Distortion		<0.1%
Working Distance Range		100 ~ 850 mm
Field of View		D (8.86 mm) : 31° H (7.37 mm) : 26° V (4.91 mm) : 17°
<b>Mechanical</b>		
Mount		S-Mount
TTL		19.3 ~ 22.2 mm
Dimension		Φ14 mm × 13.78 mm
Temperature		-10 ~ 50°C
<b>General</b>		
Certification		RoHS 2.0

**HIKROBOT**

Hangzhou Hikrobot Co. Ltd.  
en.hikrobotics.com

© Hangzhou Hikrobot Co., Ltd. All Rights Reserved.  
Hangzhou Hikrobot does not tolerate any infringement. Any organization or individual may not imitate or reproduce in whole or in part of the content. The data herein is based on Hikrobot's internal evaluation. Actual data may vary depending on specific configuration and operating condition. The information herein is subject to change without notice. All the content has been checked conscientiously. Nevertheless, Hikrobot shall not be liable to damages resulting from errors, inconsistencies or omissions.