

MVL-KF1624M-25MP 1.2" 16mm 25MP FA LENS

KF-P series FA Lens are optimized for machine vision light sources and sensors, with high resolution, excellent image uniformity, high transmittance and good stability. Featured with fixed focal length, manual aperture and compact size, it is suitable for machine vision industry applications.



Key Features

- Ultra high resolution and consistency of image clarity
- 1.2" image circle, bigger aperture, lower distortion, higher illumination relative
- Achromatic optical system design, better imaging performance with color camera
- Maintain excellent optical properties at different object distances
- Excellent vibration resistance and stability at high and low temperature performance, optical axis shifting within pixel level
- Multilayer and broadband coating design, compatible with visible and near infrared applications

Distortion

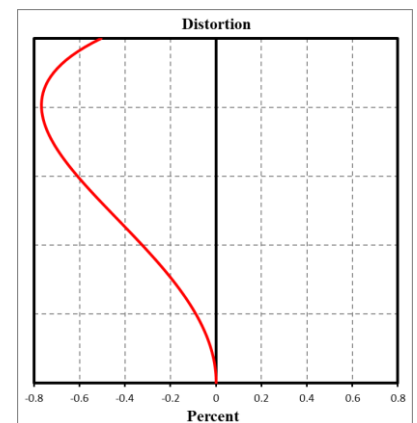

MTF

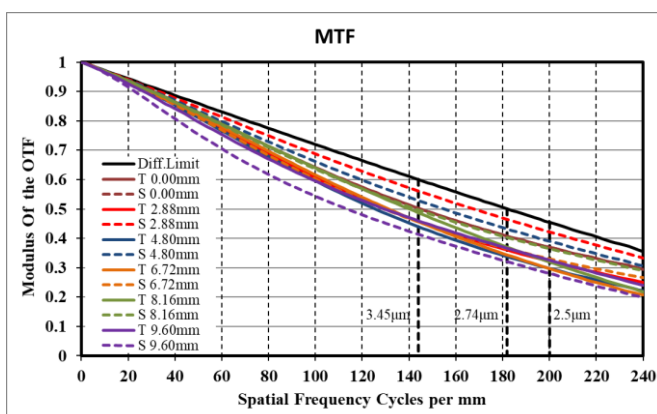

Relative Illumination

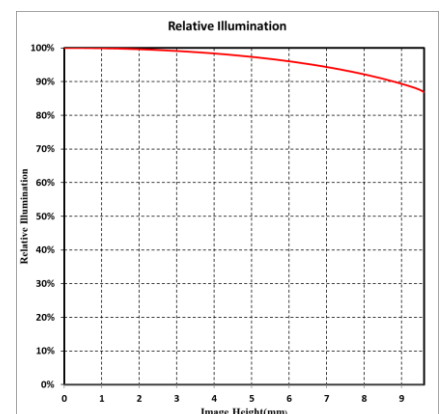

Note: The above curves are the simulate results based on F4, $\beta=-0.05$, WD=300 mm



Specification

Model	MVL-KF1624M-25MP
Parameter	Fixed focal length, Manual iris, 25MP, FA Lens
Performance	
Focal Length	16 mm
F-Number	F2.4 ~ F16
Image Size	Φ19.3 mm(1.2")
Distortion	0.07%
Minimum Object Distance	0.1 m
Field of View	D (19.30mm): 61.61° H (14.60mm): 48.82° V (12.63mm): 42.89°
Mechanical	
Iris Control	Manual
Focus Control	Manual
Filter Thread	M40.5 × 0.5
Mount	C-Mount
Flange Back Length	17.526 mm
Dimension	Φ42.5 × 59.8 mm
Weight	186 g
Temperature	-10 ~ 50°C
General	
Certification	RoHS2.0

Dimension

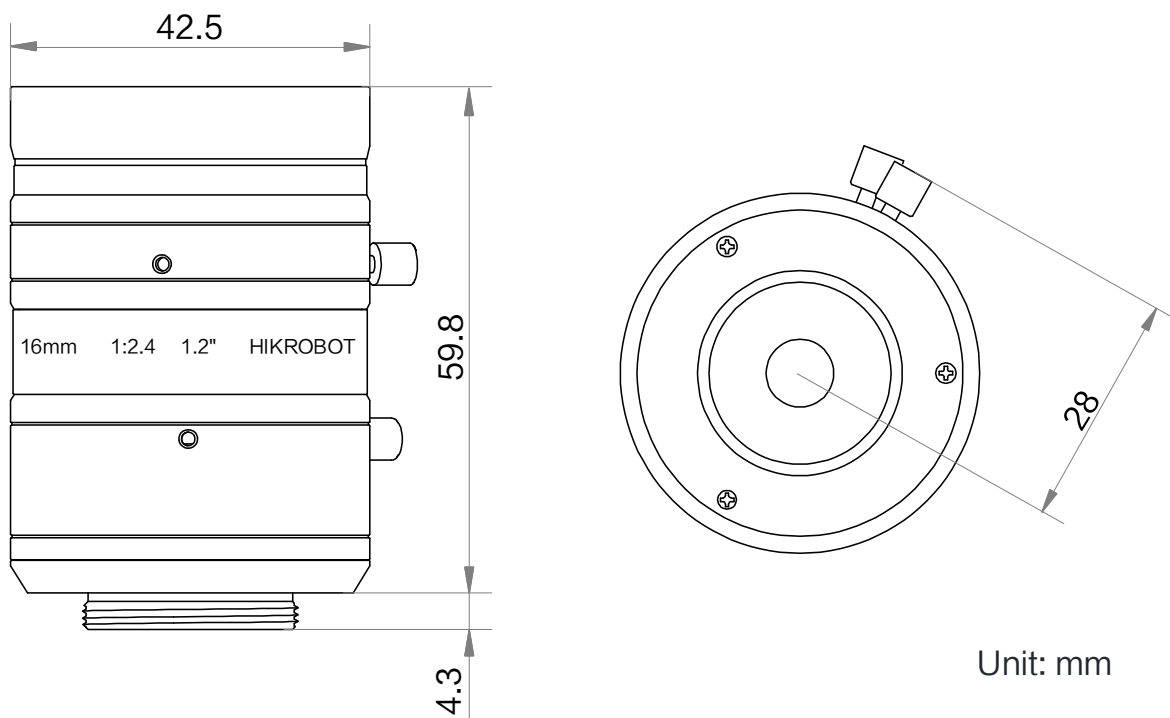

Unit: mm

Field of View

Extension (mm)	Working Distance (mm)		Magnification	Field of View (mm)					
				1.2"		1.1"		2/3"	
				H (14.6mm)	V (12.63mm)	H (14.14mm)	V (10.35mm)	H (8.45mm)	V (7.07mm)
1	near	64.71	-0.199	74.29	64.11	71.91	52.37	42.66	35.64
	far	165.05	-0.087	169.71	146.44	164.27	119.64	97.45	81.41
0		100	-0.139	106.05	91.65	102.69	74.97	61.11	51.08
		150	-0.096	152.80	132.06	147.96	108.05	88.08	73.62
		200	-0.074	199.38	172.33	193.07	141.01	114.95	96.08
		250	-0.060	245.89	212.54	238.12	173.91	141.78	118.50
		300	-0.050	292.37	252.72	283.12	206.78	168.58	140.91
		350	-0.043	338.83	292.87	328.11	239.64	195.37	163.30
		400	-0.038	385.27	333.02	373.09	272.49	222.16	185.69
		450	-0.034	431.71	373.16	418.05	305.34	248.93	208.07
		500	-0.031	478.14	413.29	463.02	338.18	275.71	230.45
		550	-0.028	524.56	453.42	507.97	371.01	302.48	252.83
		600	-0.026	570.99	493.54	552.92	403.84	329.25	275.20
		650	-0.024	617.40	533.67	597.87	436.68	356.01	297.58
		700	-0.022	663.82	573.79	642.82	469.50	382.78	319.95
		800	-0.019	756.65	654.03	732.72	535.16	436.31	364.69
	900	-0.017	849.48	734.26	822.61	600.81	489.83	409.43	
	1000	-0.016	942.30	814.49	912.49	666.46	543.36	454.17	

HIKROBOT

Hangzhou Hikrobot Co. Ltd.
en.hikrobotics.com

© Hangzhou Hikrobot Co., Ltd. All Rights Reserved.

Hangzhou Hikrobot does not tolerate any infringement. Any organization or individual may not imitate or reproduce in whole or in part of the content. The data herein is based on Hikrobot's internal evaluation. Actual data may vary depending on specific configuration and operating condition. The information herein is subject to change without notice. All the content has been checked conscientiously. Nevertheless, Hikrobot shall not be liable to damages resulting from errors, inconsistencies or omissions.