

MVL-KF5028M-12MPE

1.1" 50mm 12MP FA LENS

KF-E series FA Lens are optimized for machine vision light sources and sensor, with high resolution, excellent image quality, high transmittance and good stability. Featured with fixed focal length, manual aperture and compact size, it is suitable for machine vision industry applications and ideal for industrial cameras.



Key Features

- Ultra high resolution and consistency of image clarity
- Lower distortion
- Super high image peripheral brightness ratio
- Excellent optical properties are maintained at different object distances

Distortion

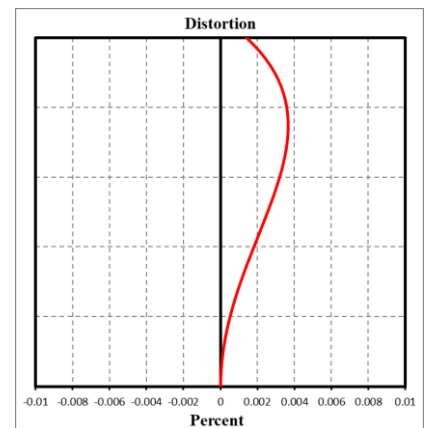

MTF

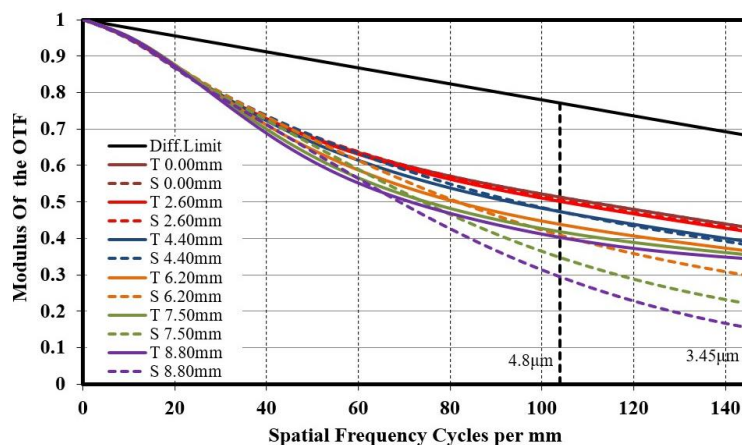

Relative Illumination

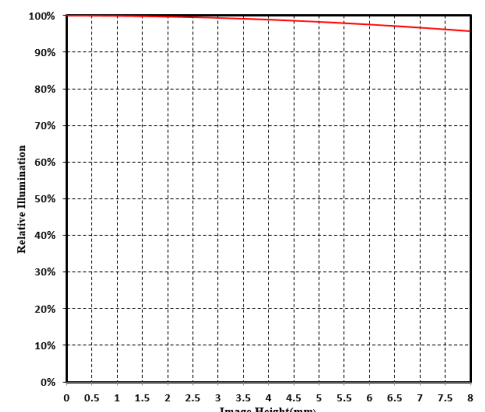

Note: The above curves are the simulate results based on F2.8, $\beta=-0.104$, WD=500 mm.



Specification

Parameter	Model	MVL-KF5028M-12MPE
	Fixed focal length, Manual iris, 12MP, FA lens	
Performance		
Focal Length	50 mm	
F-Number	F2.8 ~ F22	
Image Size	Φ17.6 mm(1.1")	
Distortion	0.04%	
Minimum Object Distance	0.3 m	
Field of View	D (17.52mm): 19.9° H (14.14mm): 15.9° V (10.35mm): 11.9°	
Mechanical		
Iris Control	Manual	
Focus Control	Manual	
Filter Thread	M35.5×0.5	
Mount	C-Mount	
Flange Back Length	17.526 mm	
Dimension	Φ38 × 53.9 mm	
Weight	121 g	
Temperature	-10 ~ 50°C	
General		
Certification	RoHS2.0	

Dimension

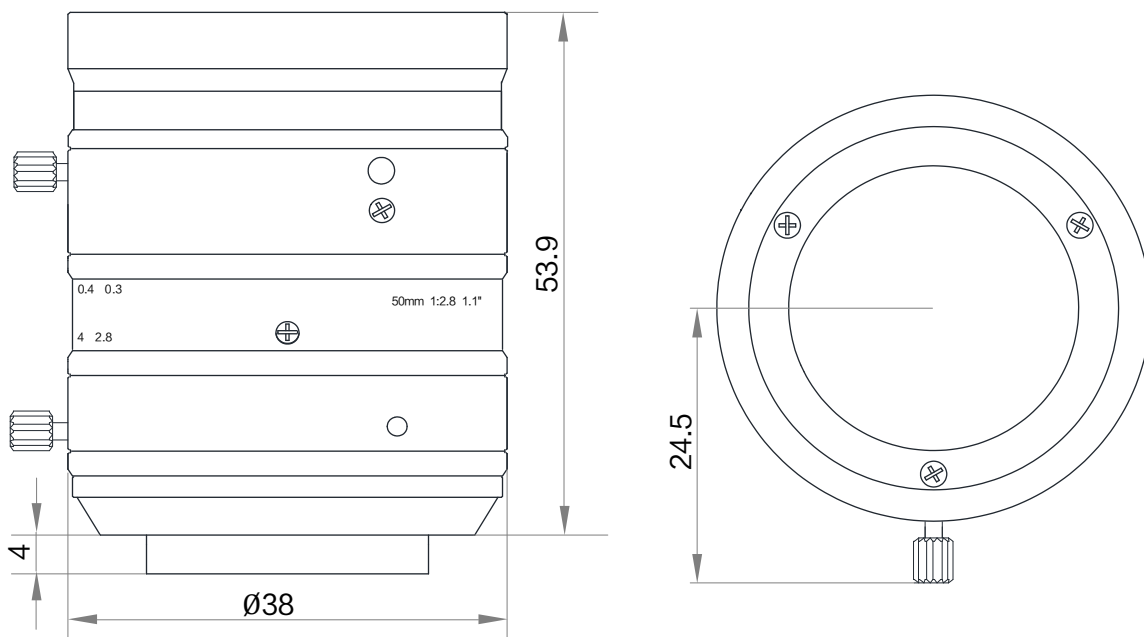

Unit: mm

Field of View

Extension (mm)	Working Distance(mm)	Magnification	Field of View(mm)					
			1.1" (14.14mm×10.35mm)		1" (12.45mm×9.83mm)		2/3" (8.45mm×7.07mm)	
			H	V	H	V	H	V
15	125.35	-0.482	29.32	21.46	25.81	20.38	17.52	14.66
	193.13	-0.296	47.77	34.97	42.06	33.21	28.55	23.89
10	152.68	-0.391	36.16	26.47	31.84	25.14	21.61	18.08
	279.23	-0.197	71.63	52.43	63.07	49.80	42.81	35.82
5	199.88	-0.280	50.50	36.96	44.46	35.11	30.18	25.25
	537.93	-0.099	143.41	104.97	126.27	99.70	85.70	71.70
2	249.24	-0.219	64.57	47.26	56.85	44.89	38.58	32.28
	1315.42	-0.039	358.88	262.69	315.99	249.49	214.47	179.44
1	272.42	-0.199	71.06	52.01	62.56	49.40	42.46	35.53
	2614.12	-0.020	717.77	525.38	631.98	498.98	428.93	358.88
0	300	-0.178	79.60	58.26	69.94	55.22	47.47	39.72
	350	-0.151	93.83	68.68	82.45	65.10	55.96	46.82
	400	-0.132	107.34	78.57	94.32	74.47	64.02	53.56
	450	-0.116	122.14	89.40	107.33	84.74	72.84	60.95
	500	-0.104	136.23	99.72	119.71	94.52	81.25	67.98
	550	-0.095	149.45	109.40	131.33	103.69	89.14	74.58
	600	-0.087	163.61	119.75	143.76	113.51	97.58	81.64
	650	-0.079	179.35	131.27	157.59	124.43	106.96	89.49
	700	-0.074	191.46	140.14	168.24	132.84	114.19	95.54
	800	-0.067	211.47	154.79	185.82	146.72	126.12	105.52
	900	-0.057	247.70	181.31	217.66	171.85	147.73	123.60
	1000	-0.052	275.11	201.37	241.75	190.87	164.08	137.28

HIKROBOT

Hangzhou Hikrobot Co. Ltd.
en.hikrobotics.com

© Hangzhou Hikrobot Co., Ltd. All Rights Reserved.

Hangzhou Hikrobot does not tolerate any infringement. Any organization or individual may not imitate or reproduce in whole or in part of the content. The data herein is based on Hikrobot's internal evaluation. Actual data may vary depending on specific configuration and operating condition. The information herein is subject to change without notice. All the content has been checked conscientiously. Nevertheless, Hikrobot shall not be liable to damages resulting from errors, inconsistencies or omissions.