

MVL-KF5028M-12MP
1.1" 50mm 12MP FA LENS

KF series FA Lens are optimized for machine vision light sources and sensors, with high resolution, excellent image uniformity, high transmittance and good stability. Featured with fixed focal length, manual aperture and compact size, it is suitable for machine vision industry applications.



Key Features

- High resolution, high definition of the whole image
- Low distortion, high illumination relative
- Maximum image circle of 1.1"
- Support ultra-short working distance, maintaining excellent optical properties at different object distances

Distortion

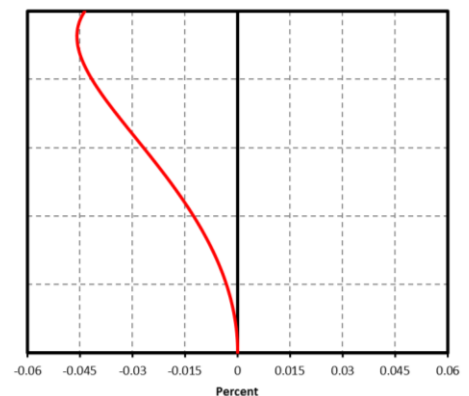

MTF

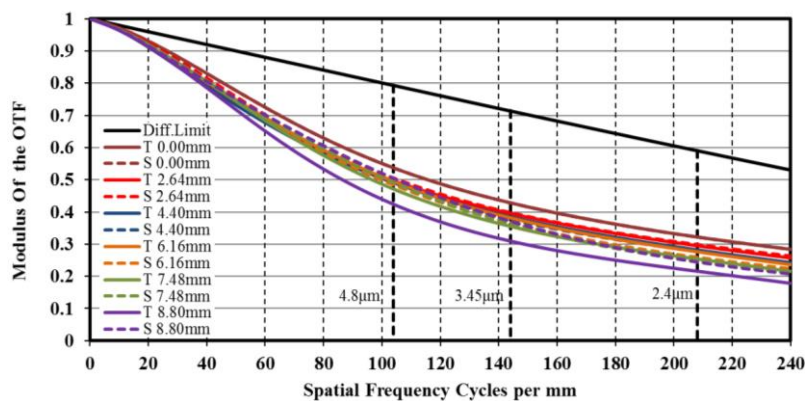

Relative Illumination

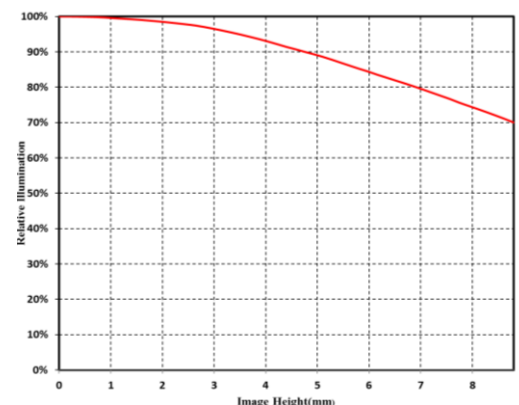

Note: The above curves are the simulate results based on F2.8, $\beta=-0.128$, WD=400 mm.



Specification

Model	MVL-KF5028M-12MP
Parameter	Fixed focal length, Manual iris, 12MP, FA Lens
Performance	
Focal Length	50 mm
F-Number	F2.8 ~ F16
Image Size	Φ17.6 mm(1.1")
Optical Distortion	-0.05%
Minimum Object Distance	0.3 m
Field of View	D (17.52mm): 18.9° H (14.14mm): 15.1° V (10.35mm): 11.2°
Mechanical	
Iris Control	Manual
Focus Control	Manual
Filter Thread	M35.5 × 0.5
Mount	C-Mount
Flange Back Length	17.526 mm
Dimension	Φ39 × 56.82 mm
Weight	134 g
Temperature	-10 ~ 50°C
General	
Certification	RoHS2.0

Dimension

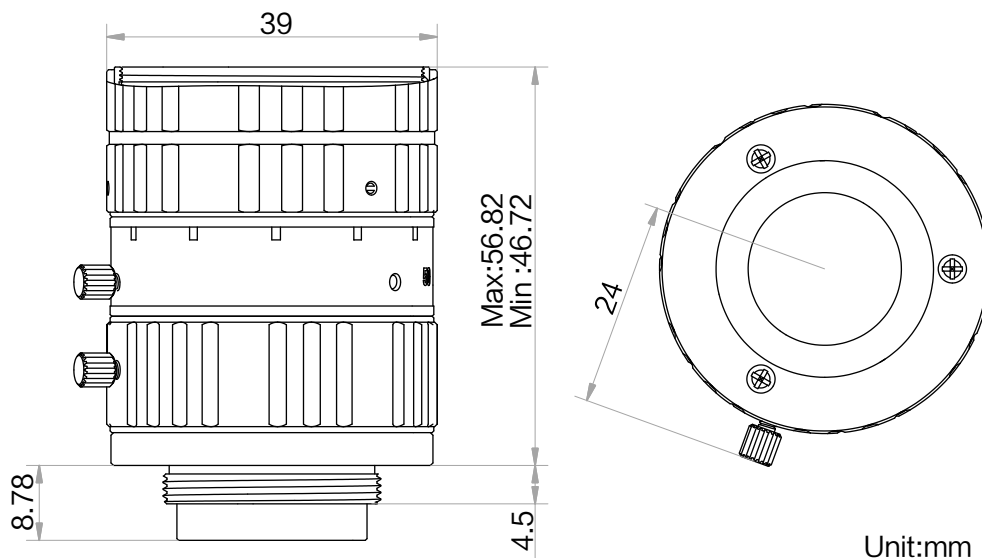

Field of View

Extension (mm)	Working Distance (mm)	Magnification	Field of View (mm)					
			1.1"		1"		2/3"	
			H (14.14mm)	V (10.35mm)	H (12.45mm)	V (9.83mm)	H (8.45mm)	V (7.07mm)
48	50	-1.179	12.00	8.78	10.56	8.34	7.17	6.00
27	75	-0.750	18.86	13.81	16.61	13.11	11.27	9.43
18	100	-0.546	25.88	18.94	22.79	17.99	15.47	12.94
9	150	-0.355	39.82	29.14	35.06	27.68	23.79	19.91
5	200	-0.262	53.90	39.46	47.46	37.47	32.21	26.95
0	250	-0.209	67.73	49.58	59.64	47.08	40.48	33.87
	300	-0.173	81.57	59.71	71.82	56.70	48.75	40.79
	350	-0.147	96.23	70.44	84.73	66.90	57.51	48.12
	400	-0.128	110.90	81.17	97.64	77.09	66.27	55.45
	450	-0.113	125.56	91.91	110.55	87.29	75.04	62.78
	500	-0.101	140.23	102.64	123.47	97.48	83.80	70.12
	550	-0.091	154.90	113.38	136.39	107.68	92.57	77.45
	600	-0.083	169.57	124.12	149.30	117.88	101.33	84.79
	650	-0.077	184.24	134.86	162.22	128.08	110.10	92.12
	700	-0.071	198.91	145.59	175.13	138.27	118.87	99.46
	750	-0.066	213.58	156.33	188.05	148.47	127.63	106.79
	800	-0.062	228.25	167.07	200.97	158.67	136.40	114.13
	850	-0.058	242.92	177.81	213.88	168.87	145.17	121.46
	900	-0.055	257.59	188.54	226.80	179.07	153.93	128.80
	950	-0.052	272.26	199.28	239.72	189.27	162.70	136.13
1000	-0.049	286.93	210.02	252.63	199.46	171.47	143.47	

HIKROBOT

Hangzhou Hikrobot Co. Ltd.
en.hikrobotics.com

© Hangzhou Hikrobot Co., Ltd. All Rights Reserved.

Hangzhou Hikrobot does not tolerate any infringement. Any organization or individual may not imitate or reproduce in whole or in part of the content. The data herein is based on Hikrobot's internal evaluation. Actual data may vary depending on specific configuration and operating condition. The information herein is subject to change without notice. All the content has been checked conscientiously. Nevertheless, Hikrobot shall not be liable to damages resulting from errors, inconsistencies or omissions.